

Sommaire

	Page
DPSM 3025 LP / Un circuit direct / Ballon ECS	2
DPSM 3025 CS / Un circuit / ECS	3
DPSM 3025 LP / Module EA107 : circuit direct et vanne / ECS	4
DPSM 3025 LP / Un Circuit / ECS Solaire	5
Cascade deux DPSM 3025 LP / Bouteille de découplage / un circuits / ECS	6

DPSM 3025 LP / Un circuit direct / Ballon ECS

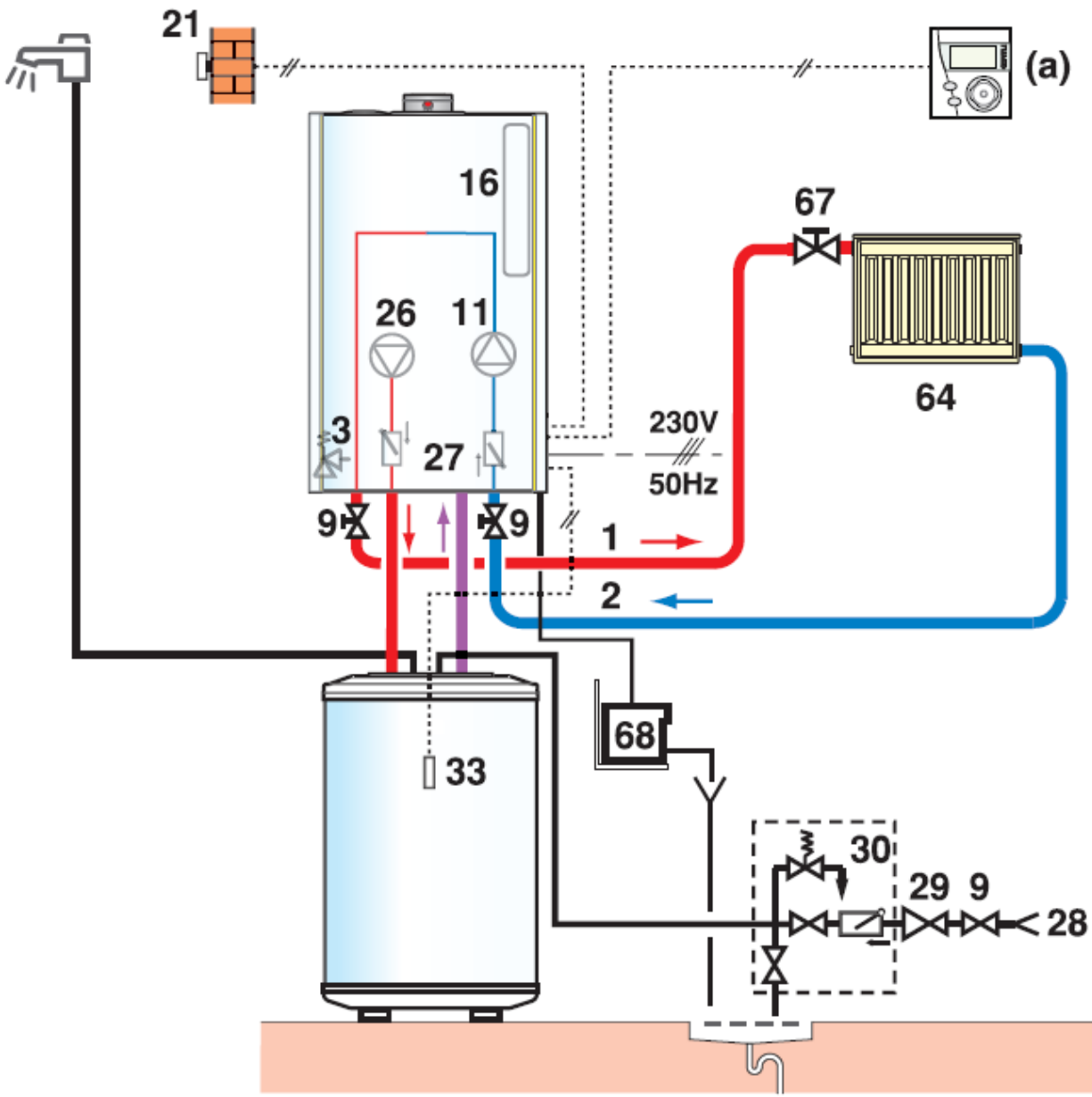

DPSM 3025 LP / Un Circuit / ECS Solaire

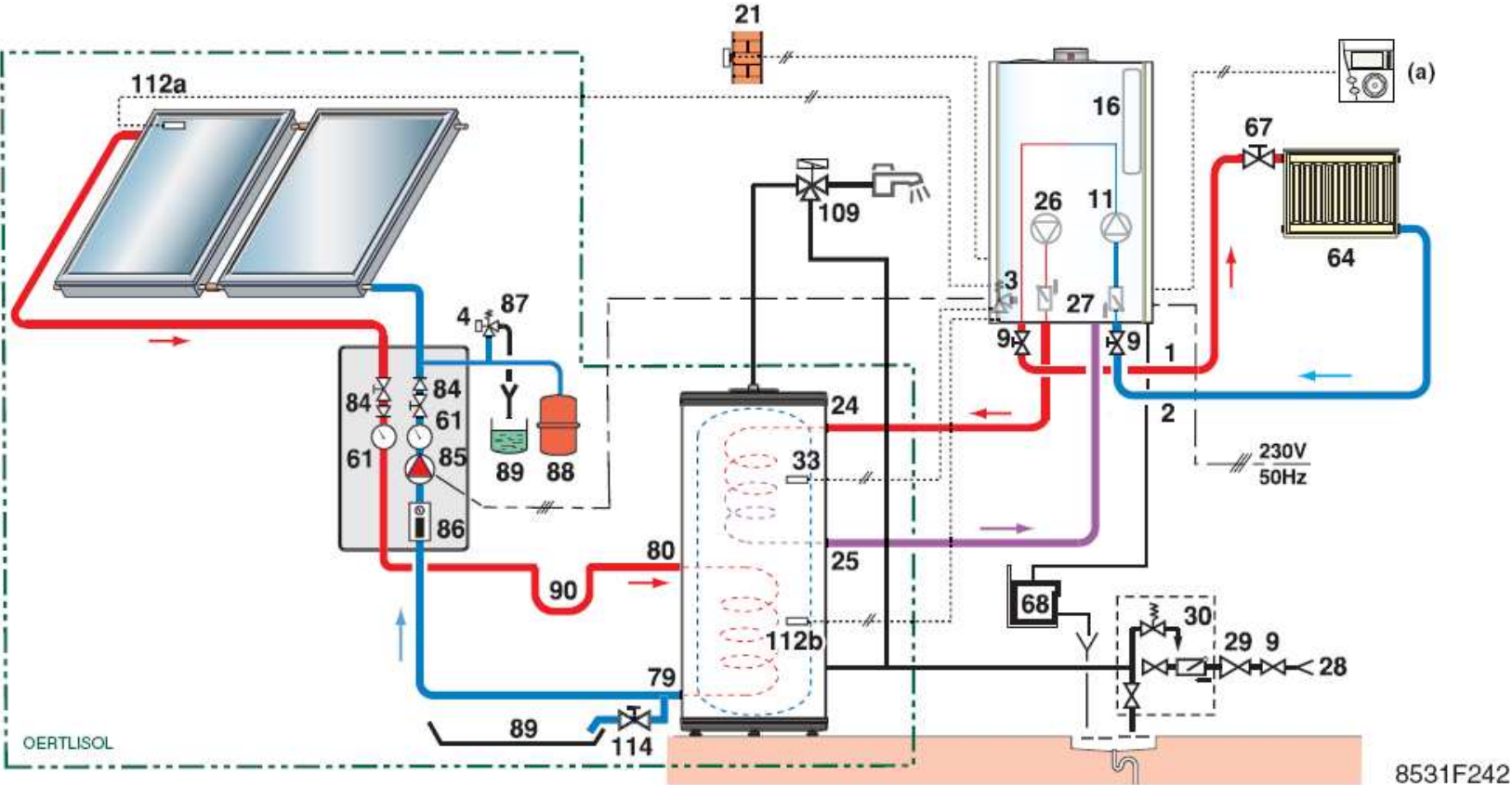

Cascade deux DPSM 3025 LP / Bouteille de découplage / Un circuit / ECS

